



Soundbar - Fitting

Installation

The Soundbar system provides all the accessories required to form a properly sealed acoustic curtain within the ceiling void. It is fixed to the soffit and walls by means of a steel angle. The angle has a foam sealing gasket which compresses against the soffit. The downward leg of the angle presents a self adhesive surface that temporarily holds the Soundbar in place, while a plain angle is used to clamp the material.

It hangs as a curtain to the partition or wall head where it is secured by the same means.

The vertical joints are butted together and covered with a self adhesive cover strip. This makes for easy and quick installation.

Offcuts can be re-used as part of the curtain or to make good gaps caused by accommodating services or other penetrations.

The top fixing angle is securely fixed to the soffit fully compressing the gasket seal. The Soundbar curtain is fixed to the downward leg. The leg has a self adhesive surface which holds the curtain for ease of installation. It is secured by a slotted clamping angle which is fixed with tec screws at a maximum of 200mm centres. (There must be a fixing at a maximum of 50mm from the edge of the curtain.) At the base a clamping angle is fixed through to the partition head. The curtain is secured to this by a clamping angle, cut to fit and compressed against the ceiling grid with all joints treated with a cover strip.

Large voids

Where a void exceeds 1200mm in depth, supporting channel section is required to be installed at 575mm centres. The Soundbar is then fixed to this and the cover strip is applied to both vertical and horizontal joints.

PLAN SECTION

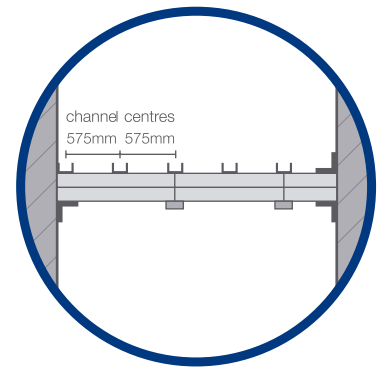

CROSS SECTION

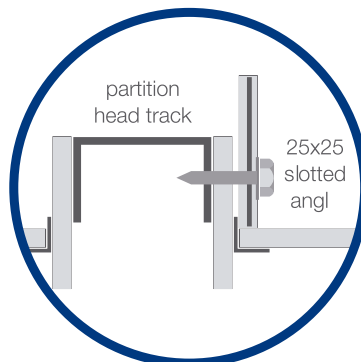
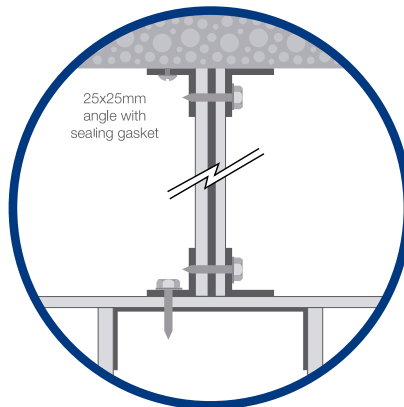
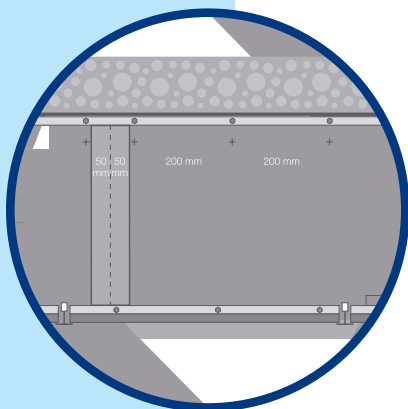
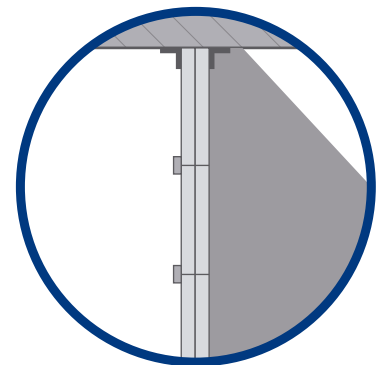

Soundbar is fixed from the soffit to the partition head. The angle can be fixed through the ceiling tile or direct onto the partition head.

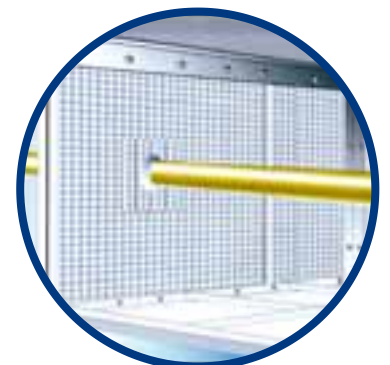

Trim Acoustics

Acoustic Barrier



Soundbar - Fitting

Penetrations

We suggest various methods to accommodate penetrations but site conditions will determine the best approach to adopt. In all situations, holes and gaps must be fully covered and all cut pieces should be securely fixed.

Soundbar should be cut as close as possible to the penetrating section and any holes or gaps may be sealed with cover strips, which are easy cut and shaped as appropriate.

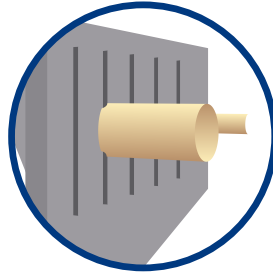

Cover strips cut and overlapped to form around a penetration.

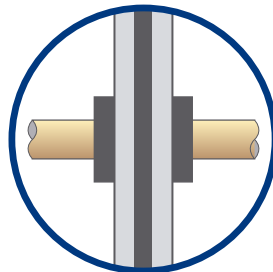

A collar can be formed out of cover strips to make a seal. They are cut to 25mm wide and coiled around the penetrating section to fill any gap between the hole and the section.

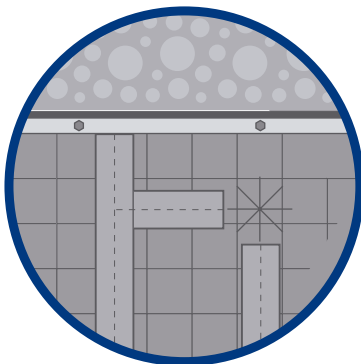

Where a single pipe or duct passes through the curtain a star cut can be made to the same diameter as the section. A further cut is made from this to the curtain edge or base.

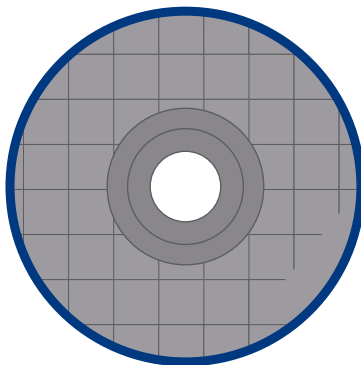

Soundbar is then formed around the section, and a cover strip is fixed over the cut, the cut being secured at the edge.

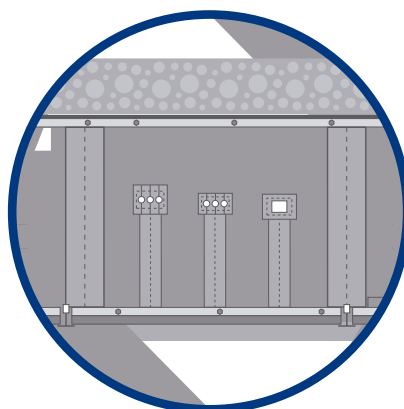

Where a number of services pass through close together, a square hole can be cut, covering the combined area of the penetrations. A cut is made from this to the bottom edge and the curtain is formed around the penetrations.

Cover strips are cut to cover the hole, these are applied by building up and overlapping to form a good seal.

Soundbar Acoustic Barrier Kit

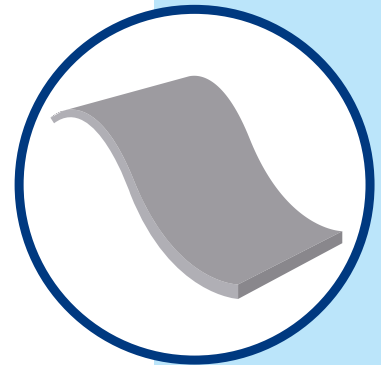

Soundbar flexible acoustic barrier.

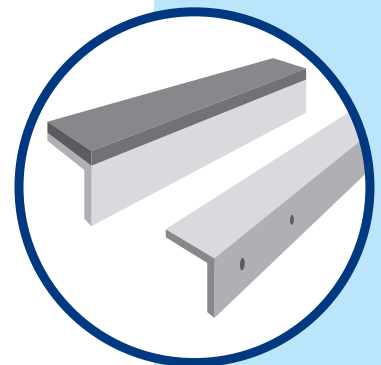

Fixing Angle with sealing gasket.
Pre-drilled Clamping Angle.